

## CHANNELS

### PLAIN CHANNEL

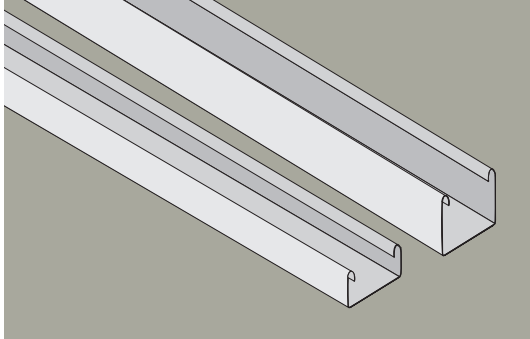

### SLOTTED CHANNEL

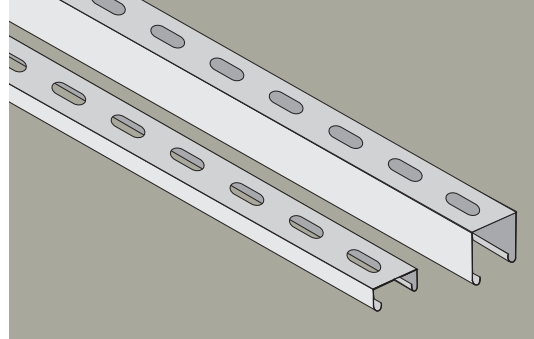

### STANDARD FINISHES

**HDG** Hot Dip Galvanized to BSEN ISO 1461:1999 (Formerly BS 729).

**PG** Pre Galvanized to BSEN 10142 & 10143.

**PC** Powder Coating to suit client requirements.

**SS** Stainless Steel finish to required grades.

### BACK TO BACK CHANNEL

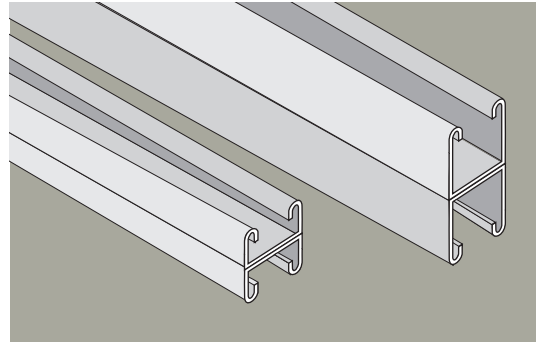

### ORDER PATTERN (mm)

TYPE	WIDTH	HEIGHT	THK	FINISH
PC/SC/BB/SS	41	21	1.5	FINISH
PC/SC/BB/SS	41	21	2.0	FINISH
PC/SC/BB/SS	41	21	2.5	FINISH
PC/SC/BB/SS	41	41	1.5	FINISH
PC/SC/BB/SS	41	41	2.0	FINISH
PC/SC/BB/SS	41	41	2.5	FINISH
PC/SC/BB/SS	41	82	2.0	FINISH
PC/SC/BB/SS	41	82	2.5	FINISH

### TYPES OF CHANNELS

**PC** Plain Channel

**SC** Slotted Channel

**BB** Back to Back Channel

**SS** Stainless Steel Channel

All channels and concrete inserts are made in standard length of 3mtrs. They can also be produced in different lengths upon request.

All Support Systems are designed to hold maximum load capacities for the entire range of Novablue Cable Management Systems.

Entire range of Support Systems are available depending on the areas of installation. These support systems are available in forms of Cantilever Arms, 'U' Supports, Brackets and Base Post Supports.

All kinds of customized Support Systems can be fabricated as per requirement.

**Note:** Request for any special sizes, gauges and flanges can be attended by our qualified team.

## CONCRETE INSERTS

ORDER PATTERN (mm)			
TYPE	WIDTH	HEIGHT	THK
CI	41	41	2.0
CI	41	41	2.5

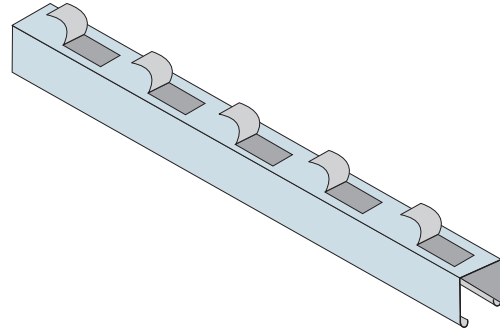

## CANTILEVER ARMS

ORDER PATTERN (mm)		
TYPE	SIZE	FINISH
CA(P/S/BB)	150	FINISH
CA(P/S/BB)	225	FINISH
CA(P/S/BB)	300	FINISH
CA(P/S/BB)	450	FINISH
CA(P/S/BB)	600	FINISH
CA(P/S/BB)	750	FINISH
CA(P/S/BB)	900	FINISH

Note: Kindly mention the Width (W), Height (H) and Thickness (T) of the channel for cantilever whilst ordering.

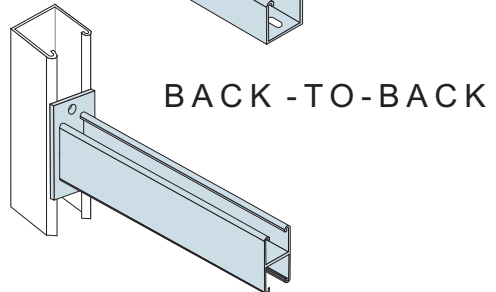
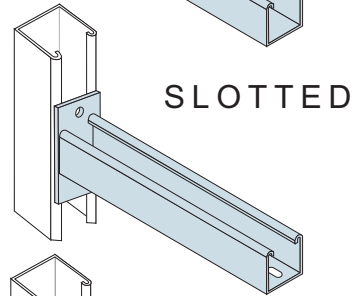
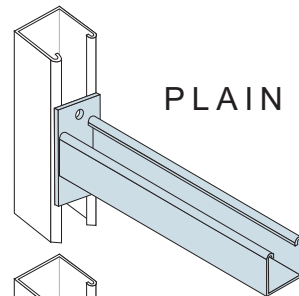

## WALL BRACKET

ORDER PATTERN (mm)		
SIZE	ITEM CODE	FINISH
100	WBR-100	FINISH
150	WBR-150	FINISH
225	WBR-225	FINISH
300	WBR-300	FINISH
450	WBR-450	FINISH
600	WBR-600	FINISH
750	WBR-750	FINISH
900	WBR-900	FINISH

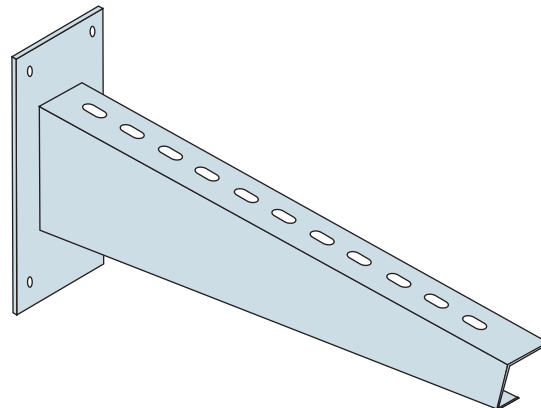

# SUPPORT SYSTEM

## FLAT PLATE

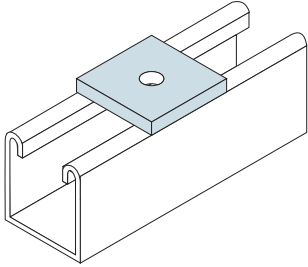

**SS-1**  
SQUARE WASHER

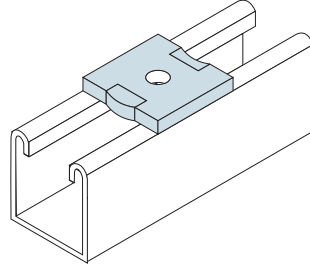

**SS-2**  
TWISTED  
SQUARE WASHER

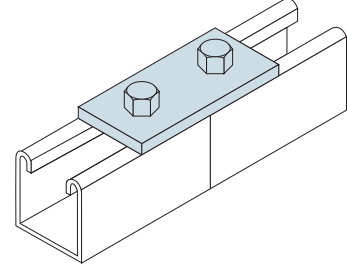

**SS-3**  
2 HOLE  
SPLICE PLATE

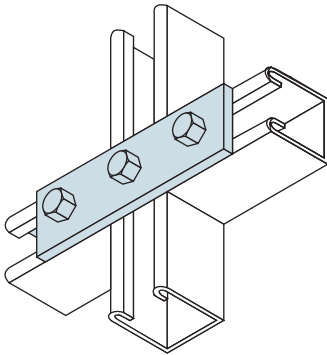

**SS-4**  
3 HOLE  
SPLICE PLATE

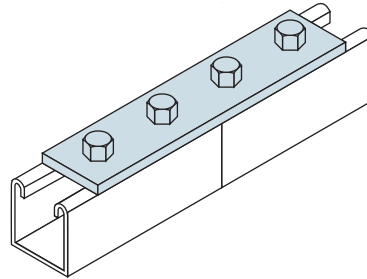

**SS-5**  
4 HOLE  
SPLICE PLATE

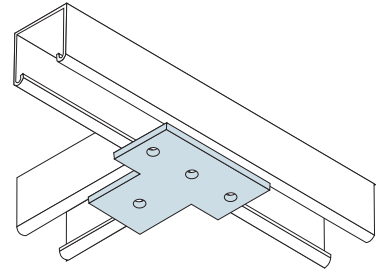

**SS-6**  
4 HOLE  
TEE PLATE

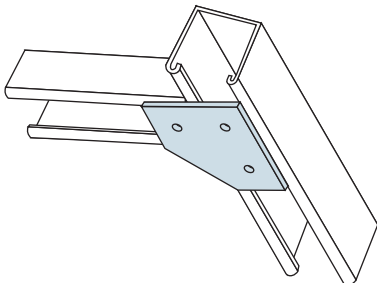

**SS-7**  
3 HOLE  
CORNER GUSSET PLATE

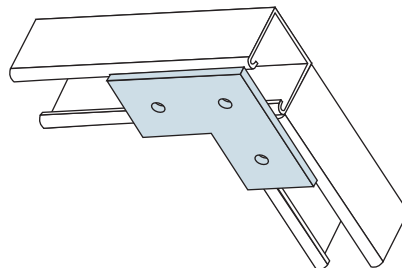

**SS-8**  
3 HOLE  
CORNER PLATE

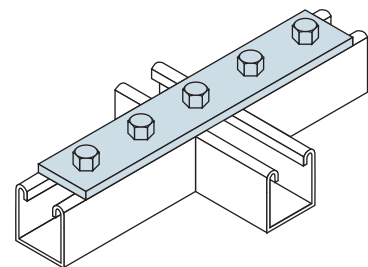

**SS-9**  
5 HOLE  
CROSS PLATE

## ANGLE FITTINGS

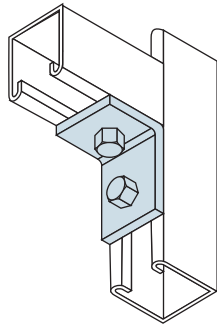

**SS-10**  
2 HOLE  
CORNER ANGLE

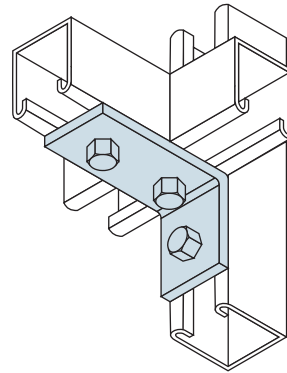

**SS-11**  
3 HOLE  
CORNER ANGLE

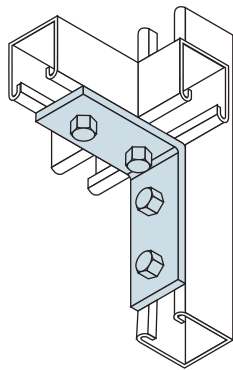

**SS-12**  
4 HOLE  
CORNER ANGLE

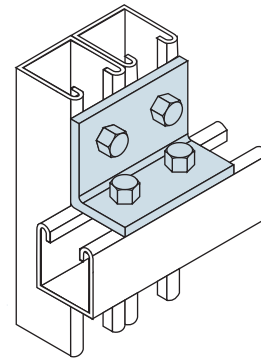

**SS-13**  
4 HOLE  
CORNER ANGLE

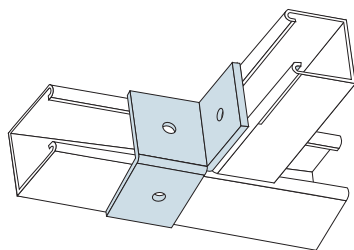

**SS-14**  
3 HOLE  
CORNER ANGLE

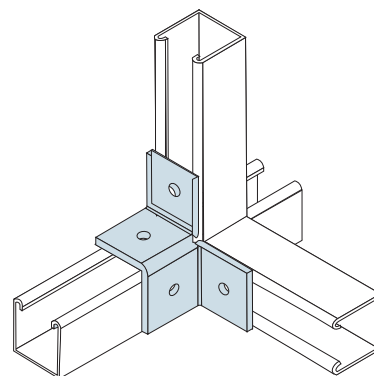

**SS-15**  
4 HOLE  
CORNER ANGLE

## “Z” AND “U” PLATE

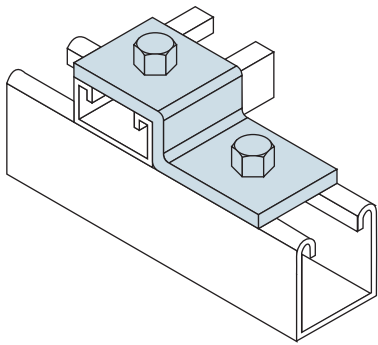

**SS-16**  
2 HOLE “Z” SUPPORT

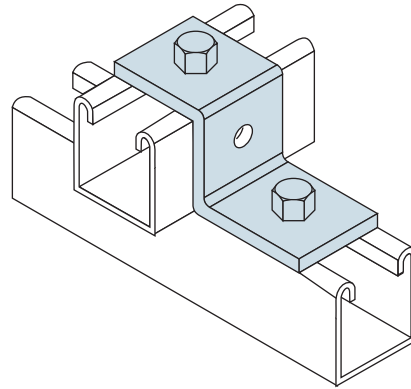

**SS-17**  
3 HOLE “Z” SUPPORT

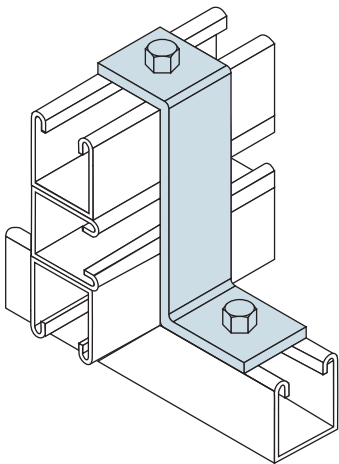

**SS-18**  
2 HOLE “Z” SUPPORT

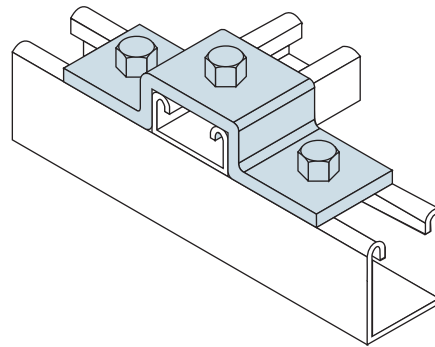

**SS-19**  
3 HOLE “U” SUPPORT

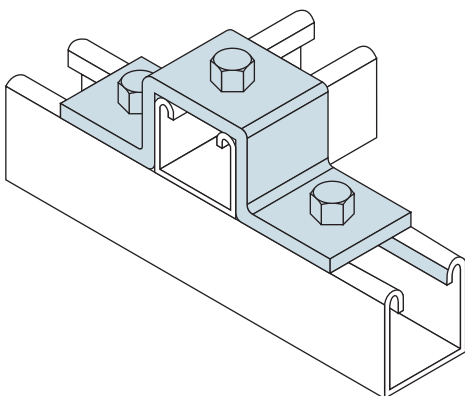

**SS-20**  
3 HOLE “U” SUPPORT

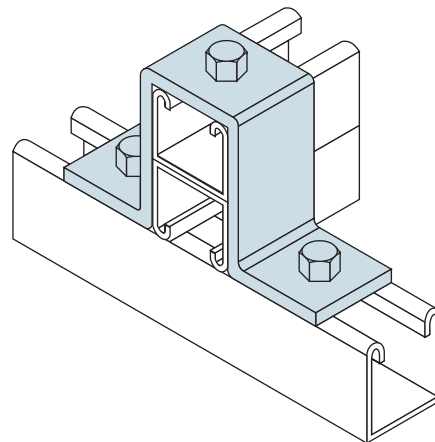

**SS-21**  
3 HOLE “U” SUPPORT

## BASE POST

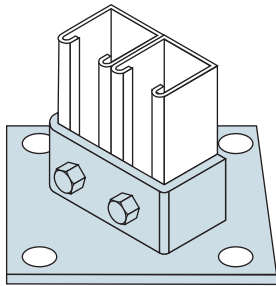

**SS-22**  
BASE POST

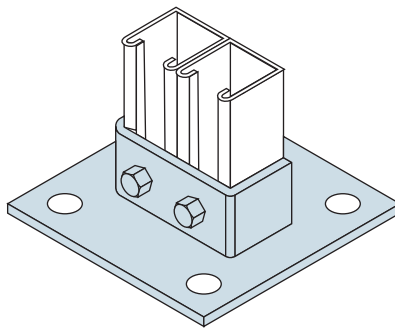

**SS-23**  
BASE POST

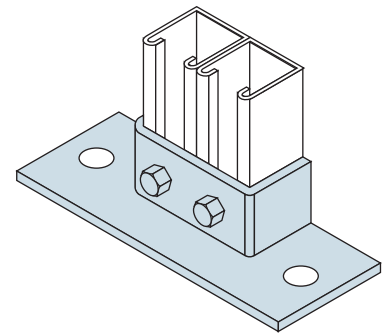

**SS-24**  
BASE POST

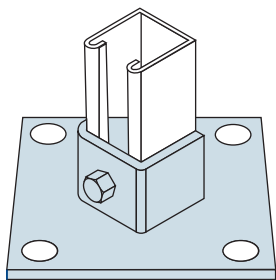

**SS-25**  
BASE POST

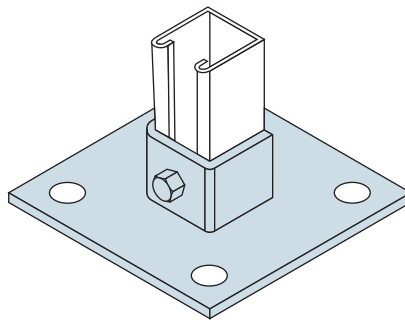

**SS-26**  
BASE POST

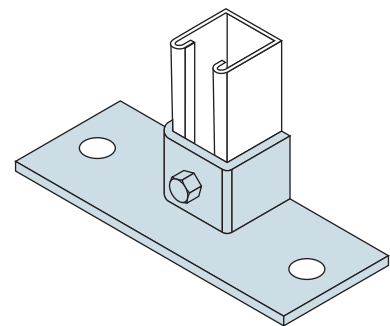

**SS-27**  
BASE POST

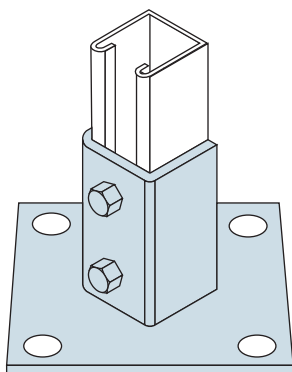

**SS-28**  
BASE POST

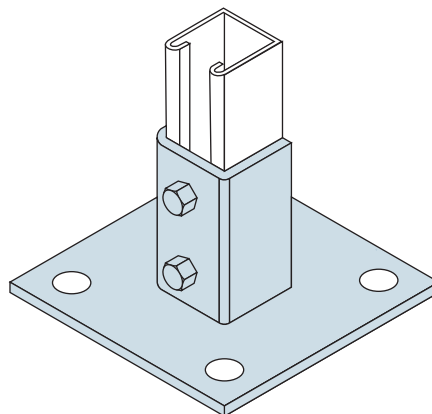

**SS-29**  
BASE POST

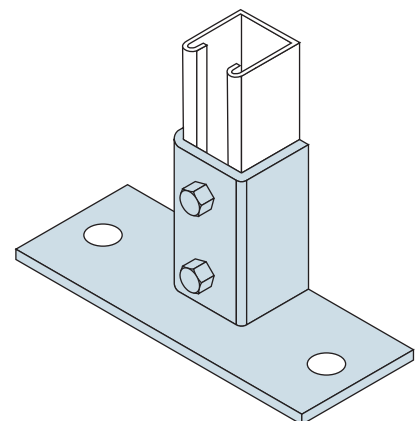

**SS-30**  
BASE POST

## OTHER FITTINGS

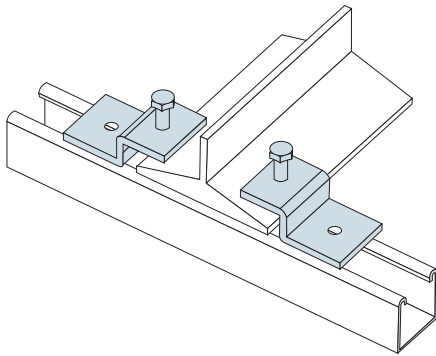

**SS-31**  
"Z" TYPE BEAM CLAMP

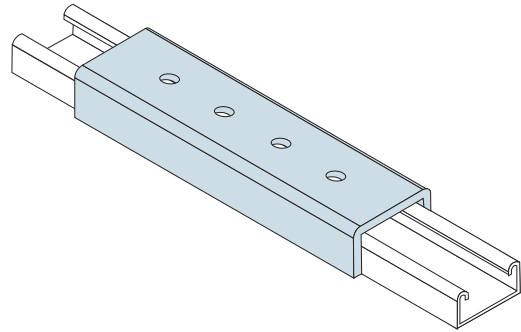

**SS-32**  
"U" CONNECTOR  
(41X21)

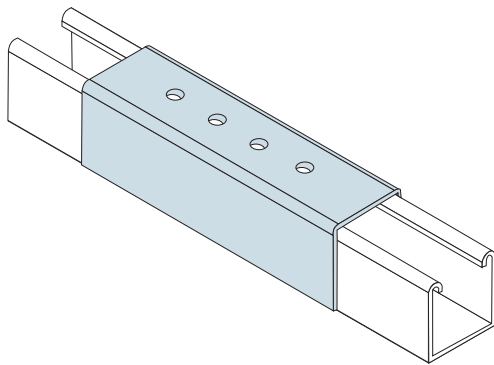

**SS-33**  
"U" CONNECTOR  
(41x41)

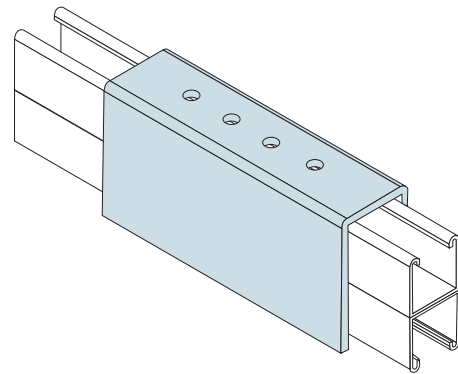

**SS-34**  
"U" CONNECTOR  
(41x82)

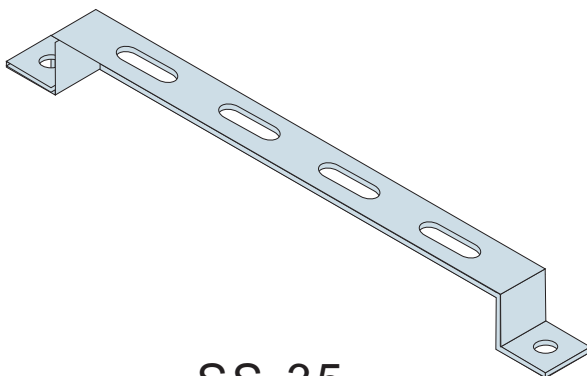

**SS-35**  
FLOOR BRACKET

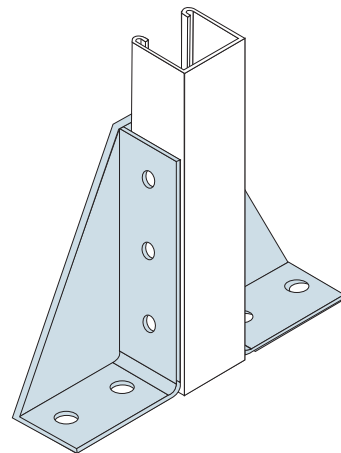

**SS-36**  
GUSSET

## THREADED RODS

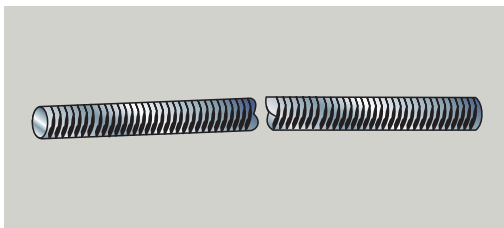

ORDER PATTERN (mm)			
SIZE	ITEM CODE		
	HDG	SS304	SS316
6	NBGTR6	NB304TR6	NB316TR6
8	NBGTR8	NB304TR8	NB316TR8
10	NBGTR10	NB304TR10	NB316TR10
12	NBGTR12	NB304TR12	NB316TR12

## STUD CONNECTORS

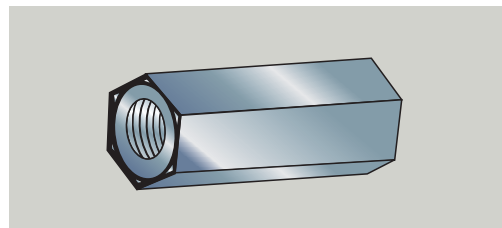

ORDER PATTERN (mm)	
SIZE	ITEM CODE
	HDG
6	NBGSC6
8	NBGSC8
10	NBGSC10
12	NBGSC12

## BOLTS

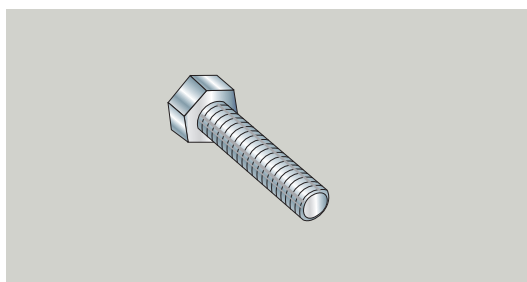

ORDER PATTERN (mm)			
SIZE	ITEM CODE		
	HDG	SS304	SS316
6X16	NBBG6X16	NBB304-6X16	NBB316-6X16
6X20	NBBG6X20	NBB304-6X20	NBB316-6X20
6X25	NBBG6X25	NBB304-6X25	NBB316-6X25
6X30	NBBG6X30	NBB304-6X30	NBB316-6X30
6X40	NBBG6X40	NBB304-6X40	NBB316-6X40
6X50	NBBG6X50	NBB304-6X50	NBB316-6X50
8X20	NBBG8X20	NBB304-8X20	NBB316-8X20
8X30	NBBG8X30	NBB304-8X30	NBB316-8X30
8X40	NBBG8X40	NBB304-8X40	NBB316-8X40
8X50	NBBG8X50	NBB304-8X50	NBB316-8X50
10X25	NBBG10X25	NBB304-10X25	NBB316-10X25
10X35	NBBG10X35	NBB304-10X35	NBB316-10X35
10X50	NBBG10X50	NBB304-10X50	NBB316-10X50
10X60	NBBG10X60	NBB304-10X60	NBB316-10X60
12X30	NBBG12X30	NBB304-12X30	NBB316-12X30
12X40	NBBG12X40	NBB304-12X40	NBB316-12X40
12X50	NBBG12X50	NBB304-12X50	NBB316-12X50
12X75	NBBG12X75	NBB304-12X75	NBB316-12X75



# SUPPORT SYSTEM

## SPRING NUTS LONG / SHORT /PLAIN

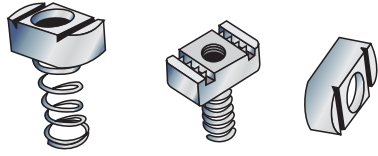

ORDER PATTERN (mm)			
SIZE	ITEM CODE		
	LONG	SHORT	PLAIN
6MM	NBLSN-6	NBSSN-6	NBPSN-6
8MM	NBLSN-8	NBSSN-8	NBPSN-8
10MM	NBLSN-10	NBSSN-10	NBPSN-10
12MM	NBLSN-12	NBSSN-12	NBPSN-12

## NUTS



ORDER PATTERN (mm)			
SIZE	ITEM CODE		
	HDG	SS 304	SS 316
6MM	NBGHN-6	NBHN 304-6	NBHN316-6
8MM	NBGHN-8	NBHN 304-8	NBHN316-8
10MM	NBGHN-10	NBHN 304-10	NBHN316-10
12MM	NBGHN-12	NBHN 304-12	NBHN316-12

## SQUARE NUTS



ORDER PATTERN (mm)	
SIZE	ITEM CODE
	HDG
6MM	NBSN-6
8MM	NBSN-8
10MM	NBSN-10
12MM	NBSN-12

## FLAT WASHER

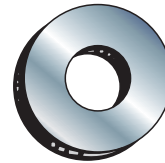

ORDER PATTERN (mm)			
SIZE	ITEM CODE		
	HDG	SS 304	SS 316
6MM	NBGW-6	NB304W-6	NB316W-6
8MM	NBGW-8	NB304W-8	NB316W-8
10MM	NBGW-10	NB304W-10	NB316W-10
12MM	NBGW-12	NB304W-12	NB316W-12

## SPRING WASHERS



ORDER PATTERN (mm)			
SIZE	ITEM CODE		
	HDG	SS 304	SS 316
6MM	NBGSW-6	NBSW304-6	NBSW316-6
8MM	NBGSW-8	NBSW304-8	NBSW316-8
10MM	NBGSW-10	NBSW304-10	NBSW316-10
12MM	NBGSW-12	NBSW304-12	NBSW316-12

## UNIFIX

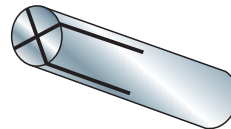

ORDER PATTERN (mm)	
SIZE	ITEM CODE
	HDG
6MM	NBUFIX-6
8MM	NBUFIX-8
10MM	NBUFIX-10
12MM	NBUFIX-12

## SCREWS

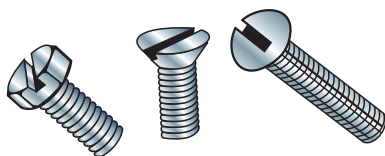

ORDER PATTERN (mm)			
SIZE	ITEM CODE		
	HDG	SS 304	SS 316
6X16	NBCG6X16	NBC304-6X16	NBC316-6X16
6X20	NBCG6X20	NBC304-6X20	NBC316-6X16
6X25	NBCG6X25	NBC304-6X25	NBC316-6X25
6X30	NBCG6X30	NBC304-6X30	NBC316-6X30
6X40	NBCG6X40	NBC304-6X40	NBC316-6X40
6X50	NBCG6X50	NBC304-6X50	NBC316-6X50
8X20	NBCG8X20	NBC304-8X20	NBC316-8-20
8X30	NBCG8X30	NBC304-8X30	NBC316-8X30
8X40	NBCG8X40	NBC304-8X40	NBC316-8X40
8X50	NBCG8X50	NBC304-8X50	NBC316-8X50
10X25	NBCG10X25	NBC304-10X25	NBC316-10X25
10X35	NBCG10X35	NBC304-10X35	NBC316-10X35
10X50	NBCG10X50	NBC304-10X50	NBC316-10X50
10X60	NBCG10X60	NBC304-10X60	NBC316-10X60
12X30	NBCG12X30	NBC304-12X30	NBC316-12X30
12X40	NBCG12X40	NBC304-12X40	NBC316-12X40
12X50	NBCG12X50	NBC304-12X50	NBC316-12X50
12X75	NBCG12X75	NBC304-12X75	NBC316-12X75

## GALVANIZED BOXES

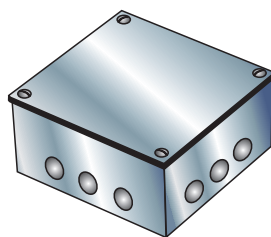

ORDER PATTERN (mm)		
SIZE		ITEM CODE
IMPERIAL	METRIC	
3X3X1.5	75X75X37.5	NBGB33-1.5
3X3X2	75X75X50	NBGB33-2
3X3X3	75X75X75	NBGB33-3
4X4X1.5	100X100X38	NBGB44-1.5
4X4X2	100X100X50	NBGB44-2
4X4X3	100X100X75	NBGB44-3
4X4X4	100X100X100	NBGB44-4
6X3X2	150X75X50	NBGB63-2
6X4X2	150X100X50	NBGB64-2
6X6X2	150X150X50	NBGB66-2
6X6X3	150X150X75	NBGB66-3
6X6X4	150X150X100	NBGB66-4
9X6X3	225X150X75	NBGB96-3
9X9X3	225X225X75	NBGB99-3